

DIN 965 FLAT PHILLIPS (TYPE H RECESS) MACHINE SCREWS							DIN 965
Nominal Diameter	Thread Pitch	A		H	M	Phillips Driver Size	
		Head Diameter		Head Height	Recess Diameter		
		Max	Min	Max	Ref		
M2.0	0.4	3.8	3.5	1.2	2.5	1	
M2.5	0.45	4.7	4.4	1.5	2.70	1	
M3.0	0.5	5.6	5.3	1.65	2.8	1	
M3.5	0.6	6.5	6.14	1.93	4.2	2	
M4.0	0.7	7.5	7.14	2.2	4	2	
M5.0	0.8	9.2	8.84	2.5	4.4	2	
M6.0	1.0	11	10.57	3	6.1	3	
M8	1.25	14.5	14.07	4	8.7	3	
Tolerance on Length	thru 3mm: ±0.20		over 3 thru 6mm: ±0.24		over 6 thru 10mm: ±0.29		
	over 10 thru 18m: ±0.35		over 18 thru 30mm: ±0.42		over 30 thru 50mm: ±0.50		

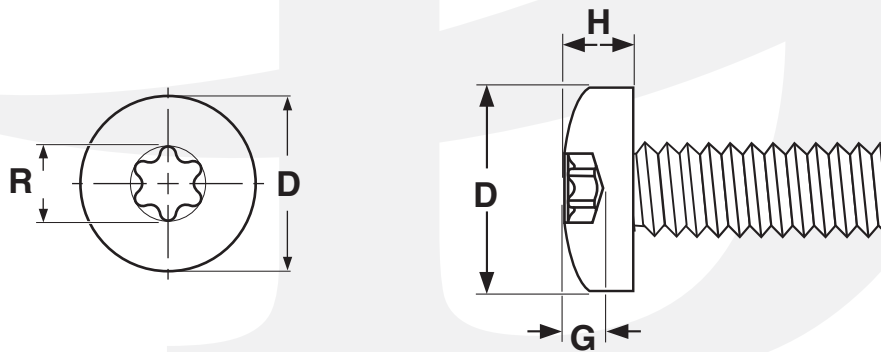

METRIC - ISO 7045 SIX-LOBE PAN HEAD MACHINE SCREWS								ISO 7045 & Camcar
Screw Size	D		H		R	G	Drive Size	
	Head Dimensions				Recess Dimensions			
	Head Diameter		Head Height		Diameter	Gauge Penetration		(Fallaway) Max Penetration
	Max	Min	Max	Min	Ref	Min		
M2	4.0	3.7	1.60	1.46	1.75	0.63	.35	T6
M2.5	5.0	4.7	2.1	1.96	2.39	0.83	.48	T8
M3	5.6	5.3	2.40	2.26	2.82	0.88	.56	T10
M4	8.00	7.64	3.10	2.92	3.94	1.27	.79	T20
M5	9.5	9.14	3.7	3.52	4.52	1.52	.90	T25